

**TOMORROW'S  
 MANUFACTURING  
 LEADERSHIP  
 TODAY**

# Technical Bulletin

Bulletin Number: 444 Revision Number: R-03

Release Date: Sept. 23, 1992 Revision Date: Nov. 8, 1993

**SUBJECT: DOUBLE DEPTH \*20 oz. PLASTIC PET BOTTLE SHIMMING**

**MODELS AFFECTED: 522T Model Series 90 Venders Only.**

**REASON: To supply a vender that will vend the 20 oz. Plastic Pet Bottle double depth.**

**SERIAL BREAK: Venders serialized 0001-3165A0 and up.**

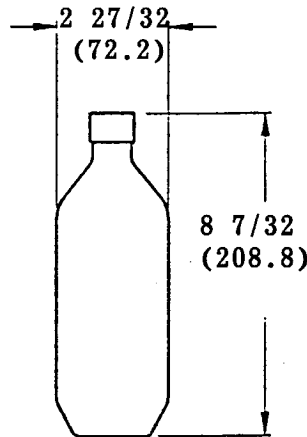

\* 20 oz. Plastic Pet Bottle

LOADING DEPTH	CAN RETAINER	SHIMS PER COLUMN	CAM SETTING	CAM FOR MOTOR	REAR SPACER LOCATION	NEW DELIVERY CHUTE
2	Use bottle neck support	0	NA	New Cam 801,806,990.01	Hole 23	324,000,200.03

NA = Not Applicable

20 oz. BOTTLE CAPACITY IN 522T	
WIDE COLUMN	50
NARROW COLUMN	NOT APPLICABLE
TOTAL	300

Order: 1 - 801,806,990.01  
1 - 324,010,140.03  
2 - 900,301,550.11  
1 - 324,000,200.03

White vending cam  
(1 per column)  
Bottle neck support  
(1 per column)  
8-32 x 1/2 sems screw  
(2 per bottle neck support)  
Assy., 20 oz. bottle chute  
(1 per vender)

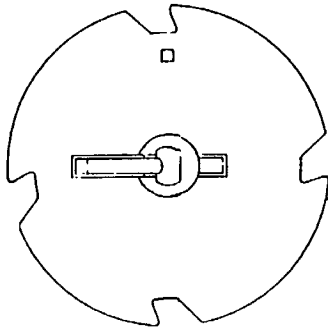

White Vending Cam  
Part #801,806,990.01  
Figure 1

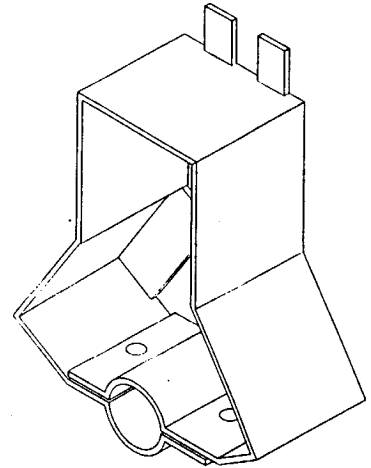

Bottle Neck Support  
Part #324,010,140.03  
Figure 2

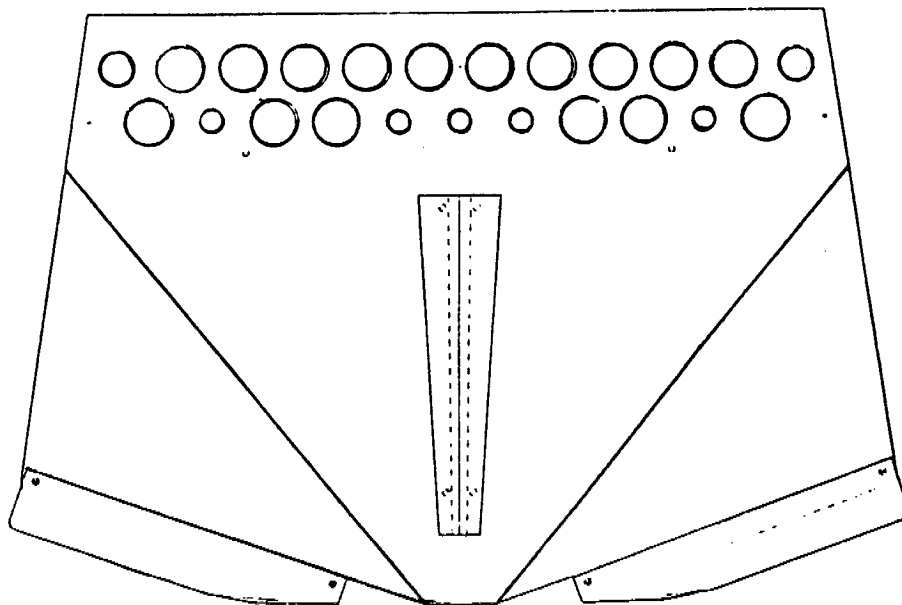

20 oz. Bottle Chute Assy.  
Part #324,000,200.03  
Figure 3

**VENDER SET-UP AND SHIMMING:**

1. Unplug the vender.
2. No shims are required.
3. Remove the can retainers from the oscillators.
4. Install the bottle neck support using figure 4.
5. Secure bottle neck support with two (2) #8-32 x 1/2 sems screws.
6. Set rear spacer in hole #23.
7. Remove existing cams from vend motors.
8. Install new white vending cam (part #801,806,990.01). See figure 1, page 2.

**Important:** The adjustable cam (gold in color) is not used. Do not place it on the motor.

9. Remove existing can/bottle delivery chute.
10. Install new can/bottle chute (part# 324,000,200.03). See figure 3, page 2.
11. Set the discharge member and closure strip for bottles.
12. Load the bottles cap to cap.

**Important:** Always load the front bottle first, then the rear bottle so the caps overlap with the rear bottle's cap on top as shown in figure 5.

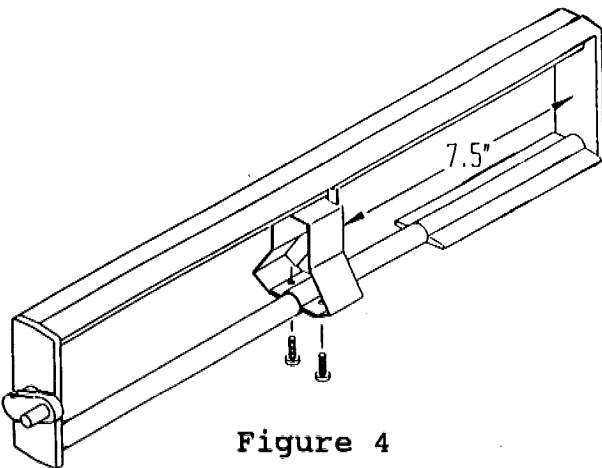

Figure 4

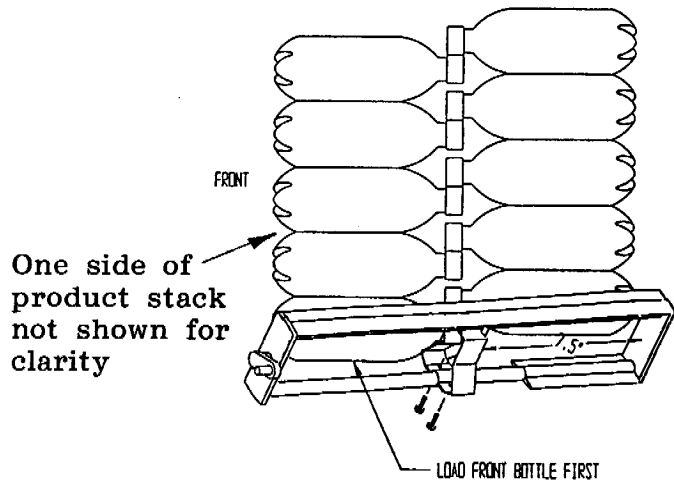

Figure 5

TB 444

Page 3 of 3